



Custom VTS Systems
***Creating a System from Scratch with the Visual
Trader Studio***

Expert Advisor General Information	2
Building Your First Expert Advisor	4
Building the “Hello World” Expert Advisor	5
Building and Using a Component, Part I	7
Building and Using a Component, Part II – Using the Real Power of a Component	11
Building an Indicator Based System	14



Expert Advisor General Information

- An Expert Advisor is built by creating an MQL file, with an extension of mq4, and then compiling the MQL file into Expert Advisor code.
- The extension of the Expert Advisor file is ex4.
- If the Alpari version of MetaTrader was installed on your PC, the folder “C:\Program Files\ MetaTrader - Alpari UK\experts” will contain both mq4 and ex4 files.
- The mq4 file is a human readable file.
- If you double click an mq4 file, the “MetaEditor” application will start and load the mq4 file.
- The MetaEditor application is part of the MetaTrader platform. It is automatically installed when the MetaTrader platform is installed.
- The “MetaEditor” application is used to edit MQL code. It has many useful features found in most code editors, including intellisense, context help and an online library.
- While editing an mq4 from within the MetaEditor, an Expert Advisor is built by clicking the “Compile” button. If there are no syntax errors, the MetaEditor application will build the ex4 file.
- The ex4 file is not a human readable file. It is binary code interpreted by the MetaTrader platform.
- So by compiling the mq4 file, you are converting the MQL language, which is human readable text, into a binary file that can be read by a machine.
- When the MetaTrader platform is started, any ex4 files in the “experts” folders are shown to be available under the “Expert Advisors” folder from the Navigator window.
- The VTS application converts its drawings into MQL code and then invokes the MetaEditor to create the ex4 file.
- When the Build button is pushed, VTS automatically creates an mq4 and ex4 file and places them in the MetaTrader platform’s “experts” directory.

iExpertAdvisor™

- If needed, the mq4 file can be edited using the MetaEditor application. Warning: Changes made by hand to an mq4 file from within the MetaEditor will be lost if the Build button is clicked from the VTS application.
 - Both the MetaEditor and Terminal applications can be run from within VTS when VTS is configured correctly.
 - If either the Terminal or MetaEditor buttons are clicked when they are selected and running, VTS will prompt to “push” the window out of the VTS application.
 - The Terminal application will be “pushed” out of the VTS application if it is running when VTS is closed. This is done to prevent Traders from inadvertently losing their MetaTrader connection.
-



Building Your First Expert Advisor

Note: Most Expert Advisors can be built using one of the Strategy Templates as a starting point. These instructions are for building a custom Expert Advisor that does not fit into any of the available Strategy Templates.

Start VTS

Double click the VTS icon.

Start a New System

- From the Welcome page, select “Expert Advisor” from the “Start New ...” window.
- This will start a new system called “System0”.
- It will create a drawing page with a Start element.

Add an EndPoint Element

- Select the “Add New Item” tab of the toolbox.
- Select and drag an Endpoint icon from the toolbox to the drawing.
- A window will appear with the EndPoint name and value.
- Select OK to accept the shown values.

Connect the Start Element and the Endpoint Element with a Link

- Move the mouse pointer over the Start element, click the left mouse button and drag the mouse pointer to the EndPoint element.
- Release the mouse button and a link will be created.

Build the Expert Advisor’s MQL Code

- Click the “Build” button along the top of the VTS main window.
- This will generate the MQL code from the VTS drawing, create a file named System0.mq4 and a file named System0.ex4 and then place the files in the MetaTrader platform’s “experts” folder.

View the MQL Code, Optional

- Click the “Editor” button along the top of the VTS main window.
- This will start the “MetaEditor” application.



Building the “Hello World” Expert Advisor

Start VTS

Double click the VTS icon.

Start a New System

- From the Welcome page, select “Expert Advisor” from the “Start New ...” window.
- This will start a new system called “SystemN”. (Where N is a number).
- It will create a drawing page with a Start element.

Save the System as “Hello World”

- From the “File” menu tab in the top left corner of the VTS application, select “File-> Save As”.
- Enter “hello world” in the text box. (Don’t enter the quotes).

Add an EndPoint Element

- Select the “Add New Item” tab of the toolbox.
- Select and drag an Endpoint icon from the toolbox to the drawing.
- A window will appear with the EndPoint name and value.
- Select OK to accept the shown values.

Add the MQL Function “Comment”

The MQL function **Comment** writes whatever (Parameter) values passed to the function to the currency chart.

- Select the “Functions” tab of the toolbox.
- Expand the ‘Common’ menu.
- Select and drag the “Comment” function to the drawing. Enter the words “hello world” into the text box. Click the “Save” button.

Connect the Start Element and the Comment Element with a Link

- Move the mouse pointer over the Start element, click the left mouse button and drag the mouse pointer to the Comment element.
- Release the mouse button and a link will be created.

Connect the Comment Element and the Endpoint Element with a Link

- Move the mouse pointer over the Comment element, click the left mouse button and drag the mouse pointer to the EndPoint element.
- Release the mouse button and a link will be created.



Build the Expert Advisor

- Click the “Build” button along the top of the VTS main window.
- This will generate the MQL code from the drawing, create a file called “Hello World.mq4” and place the file in the MetaTrader platform’s “experts” folder.
- This will also create the “Hello World.ex4” file.

View the MQL Code (Optional)

- Click the “Editor” button along the top of the VTS main window.
- This will start the “MetaEditor” application.

Attach the Expert Advisor to a Currency Chart

- Click the “Terminal” button along the top of the VTS main window. This will start the MetaTrader trading platform. If no currency chart is open, open a new one by selecting “File->New Chart”.
- From the Navigator window, expand the “Expert Advisors” menu item. Double click the “Hello World” menu item. This will attach the ‘Hello World’ Expert Advisor to the selected currency chart.
- Select “OK” to attach the Expert Advisor.

Watch for the “Hello World” Text Comment

- An Expert Advisor executes on each incoming tick of price data.
- After you attach the Expert Advisor, the words “Hello World” will be written to the top left corner of the currency chart.
- Note, in slow markets it may take some time before new price data appears.



Building and Using a Component, Part I

Start VTS

Double click the VTS icon.

Start a New System

- From the Welcome page, select “Expert Advisor” from the “Start New ...” window.
- This will start a new system called “SystemN”. (Where N is a number).
- It will create a drawing page with a Start element.

Save the System as “ShowMessage”

- From the “File” menu tab in the top left corner of the VTS application, select “File-> Save As”.
- Enter “ShowMessage” in the text box. (Don’t enter the quotes).

Create a New Component

- Select the Component icon from the Add New Item tab of the toolbox. Drag the icon onto the ShowMessage drawing pad.
- In the Create New Component window type “Show” and click OK. This will create a new drawing pad named “Show”.

Create a New Variable

- Select the Variable icon from the Add New Item tab of the toolbox. Drag the icon onto the “Show” drawing pad.
- Change the variable name to “Message”.
- Set the variable type to ALPHA.
- Set the value to the words “Hello from me!”.
- Select OK.

Add the MQL Function “Comment” to the Component “Show”

The MQL function **Comment** writes whatever (Parameter) values passed to the function to the currency chart.

- Select the “Functions” tab of the toolbox.
- Expand the ‘Common’ menu.
- Select and drag the “Comment” function to the drawing. Select the variable “Message” from the value pull-down menu. Click the “Save” button.



Add the MQL Function “Alert” to the Component “Show”

The MQL function *Alert* writes whatever (Parameter) values passed to the function to an alert message box window.

- Select the “Functions” tab of the toolbox.
- Expand the ‘Common’ menu.
- Select and drag the “Alert” function to the drawing. Select the variable “Message” from the value pull-down menu. Click the “Save” button.

Add the MQL Function “Print” to the Component “Show”

The MQL function *Print* writes whatever (Parameter) values passed to the function to the Expert Advisor log.

- Select the “Functions” tab of the toolbox.
- Expand the ‘Common’ menu.
- Select and drag the “Print” function to the drawing. Select the variable “Message” from the value pull-down menu. Click the “Save” button.

Add an EndPoint Element to the Component “Show”

- Select the “Add New Item” tab of the toolbox.
- Select and drag an Endpoint icon from the toolbox to the drawing.
- A window will appear with the EndPoint name and value.
- Select OK to accept the shown values.

Connect the Elements on the Component “Show” Drawing

- Connect Start to the Print element.
- Connect Print to the Message element.
- Connect the Message element to the Comment element.
- Connect the Comment element to the Alert element.
- Connect the Alert element to the EndPoint element.

Build the Component “Show”

- Pressing the Build button builds the currently selected Drawing.
- While viewing the “Show” drawing, click the Build button to build the Component “Show”.

Add the Component “Show” to the “ShowMessage” System

- Select the “ShowMessage” drawing by clicking on the tab titled “ShowMessage”.
- Select the Components tab of the toolbox.
- Expand the “User” menu item.
- Select the menu item named “Show”.
- Drag the “Show” component on to the “ShowMessage” drawing.



Add an EndPoint Element to the “ShowMessage” System

- Select the “Add New Item” tab of the toolbox.
- Select and drag an EndPoint icon from the toolbox to the drawing.
- A window will appear with the EndPoint name and value.
- Select OK to accept the shown values.

Connect the Elements on the “ShowMessage” System

- Connect Start to the “Show” element.
- Connect the “Show” element to the EndPoint element.

Build the “ShowMessage” System

- Pressing the Build button builds the currently selected Drawing.
- Click the Build button to build the System “ShowMessage”.

Build the “ShowMessage” Expert Advisor

- Click the “Build” button along the top of the VTS main window.
- This will generate the MQL code from the drawing, create a file called “ShowMessage.mq4” and place the file in the MetaTrader platform’s “experts” folder.

View the MQL Code (Optional)

- Click the “Editor” button along the top of the VTS main window.
- This will start the “MetaEditor” application.

Attach the Expert Advisor to a Currency Chart

- Click the “Terminal” button along the top of the VTS main window. This will start the MetaTrader trading platform. If no currency chart is open, open a new one by selecting “File->New Chart”.
- From the Navigator window, expand the “Expert Advisors” menu item. Double click the “ShowMessage” menu item. This will attach the ‘ShowMessage’ Expert Advisor to the selected currency chart.
- Select “OK” to attach the Expert Advisor.



Watch for the Messages

- An Expert Advisor executes on each incoming tick of price data.
 - After you attach the Expert Advisor, the text of the variable Message should appear on the chart, in log, and in an alert window (on every incoming tick).
 - Note, in slow markets it may take some time before new price data appears.
-



Building and Using a Component, Part II – Using the Real Power of a Component

This exercise is a continuation of the “ShowMessage” Expert Advisor. If you don’t already have the “ShowMessage” system open, select it from the “Recent Systems” window on the Welcome Page to open the system.

Open the “Show” Component

- Double click the Show element on the “ShowMessage” drawing.
- Select OK to open the component.

Change the Variable “Message”

- Select the “+” button on the bottom right hand corner of the Message element.
- This will open the variable’s configuration window.
- Check the component check box.
- This will gray out the Value field. We are going to set the value from *outside* of the “Show” component.
- Select OK.
- Build the Show component by pressing the “Build” button.

Reuse the “Show” Component

- Select the “ShowMessage” drawing by clicking on the tab titled “ShowMessage”.
- Select the Components tab of the toolbox.
- Expand the “User” menu item.
- Select the menu item named “Show”.
- Drag another copy of the “Show” component on to the “ShowMessage” drawing.
- There are now 2 “Show” elements on the “ShowMessage” drawing.
- Drag another copy of the “Show” component on to the “ShowMessage” drawing.
- There are now 3 “Show” elements on the “ShowMessage” drawing.



Configure Each “Show” Component

- Select the “+” button on the bottom right hand corner of the first “Show” element.
- In the text field, enter “Hello from number 1”.
- Select save button to save the component.

- Select the “+” button on the bottom right hand corner of the second “Show” element.
- In the text field, enter “Hello from number 2”.
- Select save button to save the component.

- Select the “+” button on the bottom right hand corner of the third “Show” element.
- In the text field, enter “Hello from number 3”.
- Select save button to save the component.

Connect the Elements on the “ShowMessage” System

- Note: To delete a link, select it with the mouse and press the delete key on your keyboard.
- Delete the original links from Part 1.
- Connect Start to the first “Show” element.
- Connect the first and second “Show” element to each other.
- Connect the second and third “Show” element to each other.
- Connect the third “Show” element to the EndPoint element.

Build the “ShowMessage” System

- Pressing the Build button builds the currently selected Drawing.
- Click the Build button to build the System “ShowMessage”.
- This will generate the MQL code from the drawing, create a file called “ShowMessage.mq4” and place the file in the MetaTrader platform’s “experts” folder.

View the MQL Code

- Click the “Editor” button along the top of the VTS main window.
- This will start the “MetaEditor” application.



Attach the Expert Advisor to a Currency Chart

- Click the “Terminal” button along the top of the VTS main window. This will start the MetaTrader trading platform. If no currency chart is open, open a new one by selecting “File->New Chart”.
- From the Navigator window, expand the “Expert Advisors” menu item. Double click the “ShowMessage” menu item. This will attach the ‘ShowMessage’ Expert Advisor to the selected currency chart.
- Select “OK” to attach the Expert Advisor.

Watch for the Messages

- An Expert Advisor executes on each incoming tick of price data.
 - After you attach the Expert Advisor, the text of the variable Message should appear on the chart, in log, and in an alert window (on every incoming tick).
 - You will see a message from each of the Components.
 - Note, in slow markets it may take some time before new price data appears.
-



Building an Indicator Based System

- This is a simple Expert Advisor that will open a Buy position if the ADX level is above a defined level or open a Sell position if the ADX is below a defined level.
- The Expert will only open one trade at a time.
- Each position will be opened using the limit parameters (stoploss, takeprofit, etc) that are passed in as variables.

Start VTS

Double click the VTS icon.

Start a New System

- From the Welcome page, select “Expert Advisor” from the “Start New ...” window.
- This will start a new system called “SystemN”. (Where N is a number).
- It will create a drawing page with a Start element.

Save the System as “IndicatorSystem”

- From the “File” menu tab in the top left corner of the VTS application, select “File-> Save As”.
- Enter “IndicatorSystem” in the text box. (Don’t enter the quotes).

The QsOpenOrderInfo Function

- The function QsOpenOrderInfo is a function written by the developers of VTS.
- It stores the state of the latest open trade in variables that are accessible from anywhere in the System.
- The variables can be viewed in the ToolBox. Select the Variables tab and click the “Open Trade Info” menu item.
- The variables are:
 - TotalTrades
 - TotalTradeLots
 - TotalTradeSwap
 - TotalTradeProfit
 - LastTradeOpenPrice
 - LastTradeOpenTime
 - LastTradeStopLoss
 - LastTradeTakeProfit
 - LastOrderType
 - LastOrderTicket
 - LastTradeSymbol
 - LastTradeComment
- The QsOpenOrderInfo function is available from all of the QuickStart Strategy Systems.
- To use the QsOpenOrderInfo function in a custom system, the function must be added to the Library from within one of the QuickStart Strategy Systems.
- From within one of the QuickStart Strategy Systems, select the QsOpenOrderInfo function in the ToolBox and press the right mouse button. The following window will be displayed:

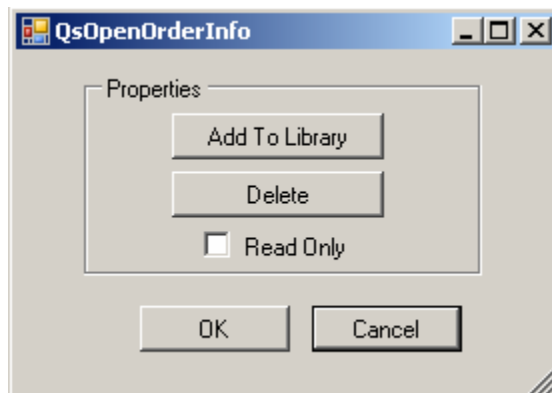

- Click the “Add To Library” button to add the QsOpenOrderInfo function to the Library.

iExpertAdvisor™

- The QuickStart Strategy System may now be closed. The QsOpenOrderInfo function is now available to all systems from the Library.
- The QsOpenOrderInfo function can be added to a custom system by selecting it from the Functions Toolbox under the “Lib” menu.
- After the QsOpenOrderInfo function has been added to the drawing, at least one Symbol must be added to the function. Click the “+” button on the bottom left corner of the element. The following window will be displayed:

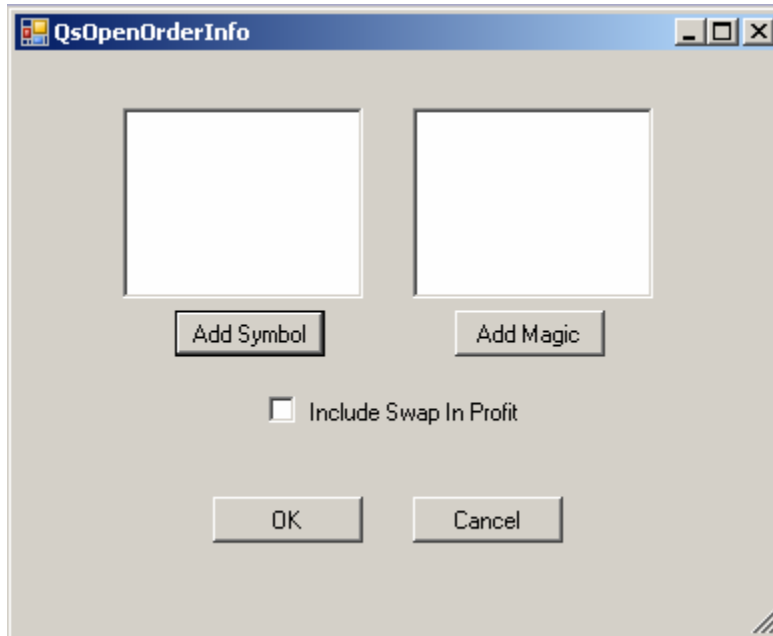

- Clicking the “Add Symbol” button will display the following window:

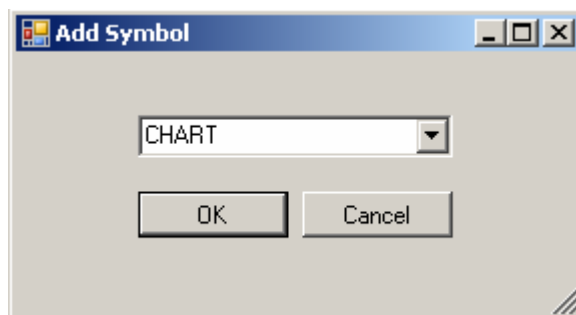

- Select OK to choose a Symbol.

Create the OkToTrade Component

- This component is used to determine if the system is allowed to open any trades.
- Select the “Add New Item” tab of the toolbox.
- Select and drag the Component icon from the toolbox to the drawing.
- Enter “OkToTrade” and select OK to start a new component.
- A new diagram name “OkToTrade” will be created. Elements will be added to this diagram.

Add the fnGetOpenTradeInfo Function to the “OkToTrade” Drawing

- Select the “Functions” tab of the ToolBox.
- Click the “Library” menu item.
- Select the fnGetOpenTradeInfo menu item and drag it on to the “OkToTrade” drawing.

Add a Logic Element to the Drawing

- Select the “Add New Item” tab of the ToolBox.
- Select the “Logic” icon and drag it on to the “OkToTrade” drawing.
- Click the “+” button on the bottom left corner of the element. The following window will be displayed:

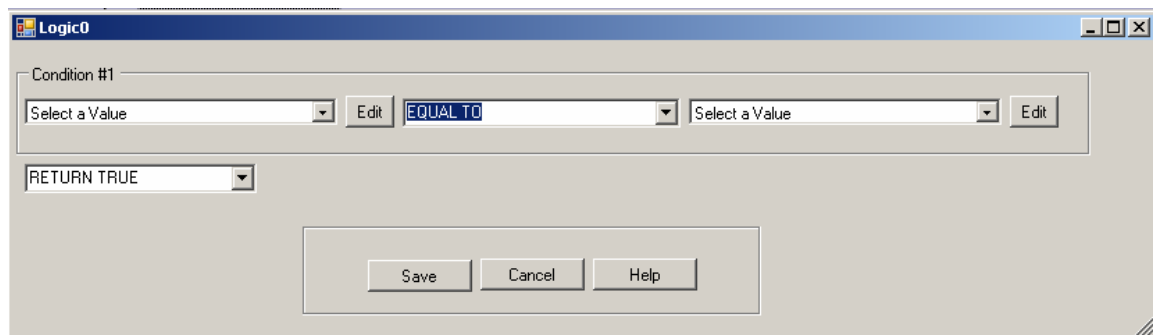

- From the center pull-down menu, select “GREATER THAN”.
- From the left hand pull-down menu select the “TotalTrades” variable.

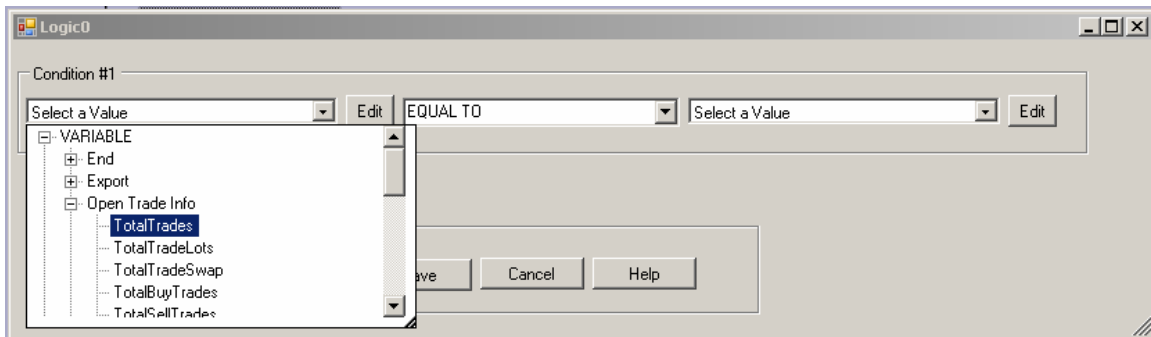

- From the right hand pull-down menu enter the value 0.
- The window should look like this when complete.

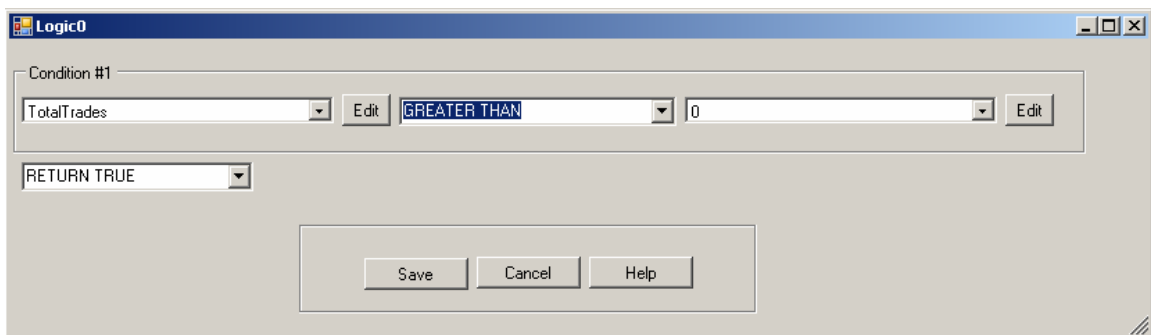

- Select Save.

Add a TRUE EndPoint Element to the “OkToTrade” Drawing

- Select the “Add New Item” tab of the toolbox.
- Select and drag an Endpoint icon from the toolbox to the drawing window will appear with the EndPoint name and value.
- Select “True” from the pull-down menu. (It’s probably already set to True).
- Select OK to accept the shown values.

Add a FALSE EndPoint Element to the “OkToTrade” Drawing

- Select the “Add New Item” tab of the toolbox.
- Select and drag an Endpoint icon from the toolbox to the drawing.
- A window will appear with the EndPoint name and value.
- Select “False” from the pull-down menu.
- Select OK to accept the shown values.

Connect the Elements on the “OkToTrade” Drawing

- Connect the Start element to the QsOpenOrderInfo element.
- Connect the QsOpenOrderInfo element to the Logic0 element.
- Connect the “true” connector of the Logic0 element to the True Endpoint element.
- Connect the “false” connector of the Logic0 element to the False Endpoint element.
- The drawing should look similar to this:

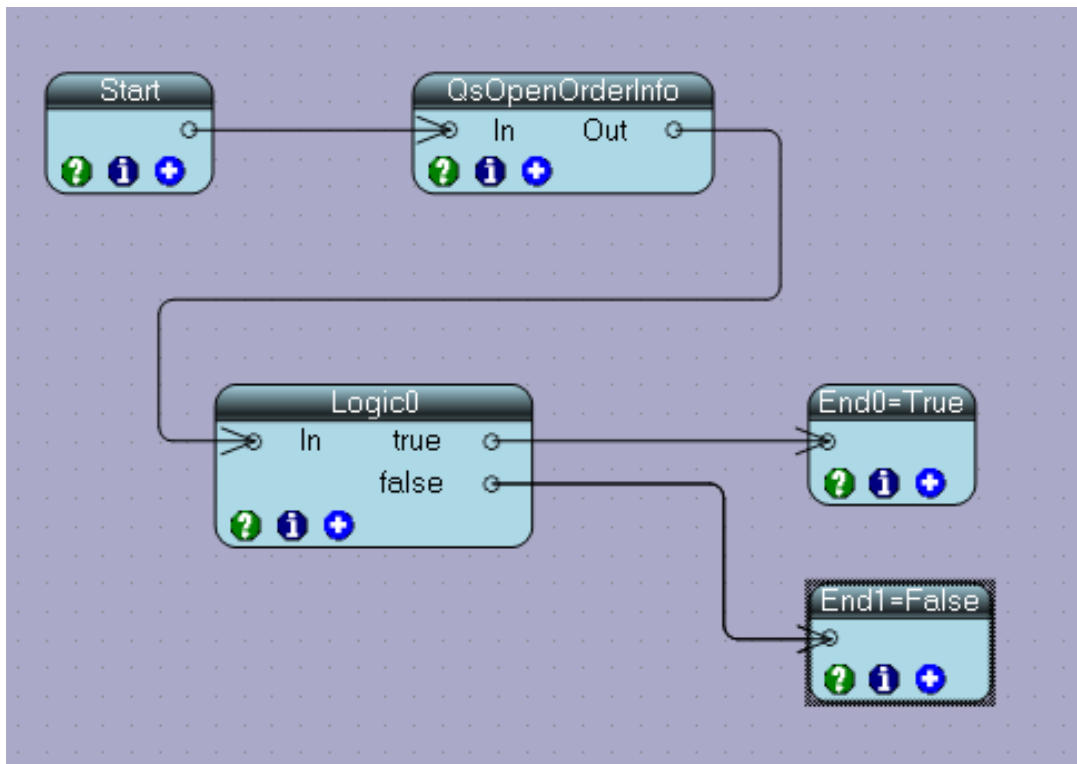

- This drawing performs this logic:
 - Executes the function QsOpenOrderInfo which will set the TotalTrades variable to the number of trades currently open for the account.
 - Compares the TotalTrades variable with Zero.
 - If the variable TotalTrades is greater than zero, the component ends with, or returns, the value False.
 - If the variable TotalTrades is NOT greater than zero, the component ends with, or returns, the value True.

If the Component “OkToTrade” returns true, it is OK to trade. If it returns false, it is not OK to trade.

© 2008 iExpertAdvisor Corporation. All rights reserved.

iExpertAdvisor is a registered trademark of iExpertAdvisor, LLC in the USA and/or other countries.



Build the “OkToTrade” Component/Drawing

- With the “OkToTrade” drawing open, click the “Build” button on the upper right portion of the VTS application.
 - The log file on the bottom of the VTS application will display the results of the build.
-

Create the GetTradeSignal Component

- This component will use the value of an indicator to determine if a trade should be opened.
- Select the “Add New Item” tab of the toolbox.
- Select and drag the Component icon from the toolbox to the drawing.
- Enter “GetTradeSignal” and select OK to start a new component.
- A new diagram name “GetTradeSignal” will be created. Elements will be added to this diagram.

Create a New Variable named OpenLongPosition

- Select the “Add New Item” tab of the ToolBox.
- Select the “Variable” icon and drag it on to the “GetTradeSignal” drawing.
- Enter “OpenLongPosition” for the name.
- Leave the type as Numeric.
- Set the value to “100” (that is the number 100, with no quotes).
- Select OK.

Create a New Variable named OpenShortPosition

- Select the “Add New Item” tab of the ToolBox.
- Select the “Variable” icon and drag it on to the “GetTradeSignal” drawing.
- Enter “OpenShortPosition” for the name.
- Leave the type as Numeric.
- Set the value to 200.
- Select OK.



Create a New Variable named AdxBuyLevel

- Select the “Add New Item” tab of the ToolBox.
- Select the “Variable” icon and drag it on to the “GetTradeSignal” drawing.
- Enter “AdxBuyLevel” for the name.
- Leave the type as Numeric.
- Set the value to 50.0.
- Check the “Export” box. This will allow this variable to be set when attaching the Expert Advisor to a chart.
- The variable may now be deleted from the drawing. It can be referenced by the Logic Element.
- Select OK.

Create a New Variable named AdxSellLevel

- Select the “Add New Item” tab of the ToolBox.
- Select the “Variable” icon and drag it on to the “GetTradeSignal” drawing.
- Enter “AdxSellLevel” for the name.
- Leave the type as Numeric.
- Set the value to 15.0.
- Check the “Export” box. This will allow this variable to be set when attaching the Expert Advisor to a chart.
- The variable may now be deleted from the drawing. It can be referenced by the Logic Element.
- Select OK.

Add an OpenLongPosition EndPoint Element to the “GetTradeSignal” Drawing

- Select the “Add New Item” tab of the toolbox.
- Select and drag an Endpoint icon from the toolbox to the drawing.
- A window will appear with the EndPoint name and value.
- Select “OpenLongPosition” from the pull-down menu. (It will probably be at or near the bottom of the selection list).
- Select OK to accept the shown values.

Add an OpenShortPosition EndPoint Element to the “GetTradeSignal” Drawing

- Select the “Add New Item” tab of the toolbox.
- Select and drag an Endpoint icon from the toolbox to the drawing.
- A window will appear with the EndPoint name and value.
- Select “OpenShortPosition” from the pull-down menu. (It will probably be at or near the bottom of the selection list).
- Select OK to accept the shown values.



Add the Indicator New Function

- Select the “Functions” tab of the toolbox.
- Select the “Indicators” menu item.
- Select and the iAdx menu item and drag it onto the “GetTradeSignal” drawing.
- Select OK to accept the default parameters for the iAdx function.

Add a Logic Element to the “GetTradeSignal” Drawing

- Select the “Add New Item” tab of the ToolBox.
- Select the “Logic” icon and drag it on to the “GetTradeSignal” drawing.
- From the left and pull-down menu select the “iAdx0” function.
- From the pull-down menu, select “GREATER THAN”.
- From the right hand pull-down menu select the “AdxBuyLevel” function.
- Select OK.

Add Another Logic Element to the “GetTradeSignal” Drawing

- Select the “Add New Item” tab of the ToolBox.
- Select the “Logic” icon and drag it on to the “GetTradeSignal” drawing.
- From the left and pull-down menu select the “iAdx0” function.
- From the pull-down menu, select “LESS THAN”.
- From the right hand pull-down menu select the “AdxSellLevel” function.
- Select OK.

Connect the Elements on the “GetTradeSignal” Drawing

- Connect the Start element to the OpenLongPosition variable element. (This will set the value of OpenLongPosition to 100.)
- Connect the OpenLongPosition variable element to the OpenShortPosition variable element. (This will set the value of OpenShortPosition to 200.)
- Connect the “true” connector of the Logic0 element to the OpenLongPosition Endpoint.
- Connect “true” connector of the Logic1 element to the OpenShortPosition Endpoint.
- Connect “false” connector of the Logic1 element to the False Endpoint.
- The drawing should look similar to this:

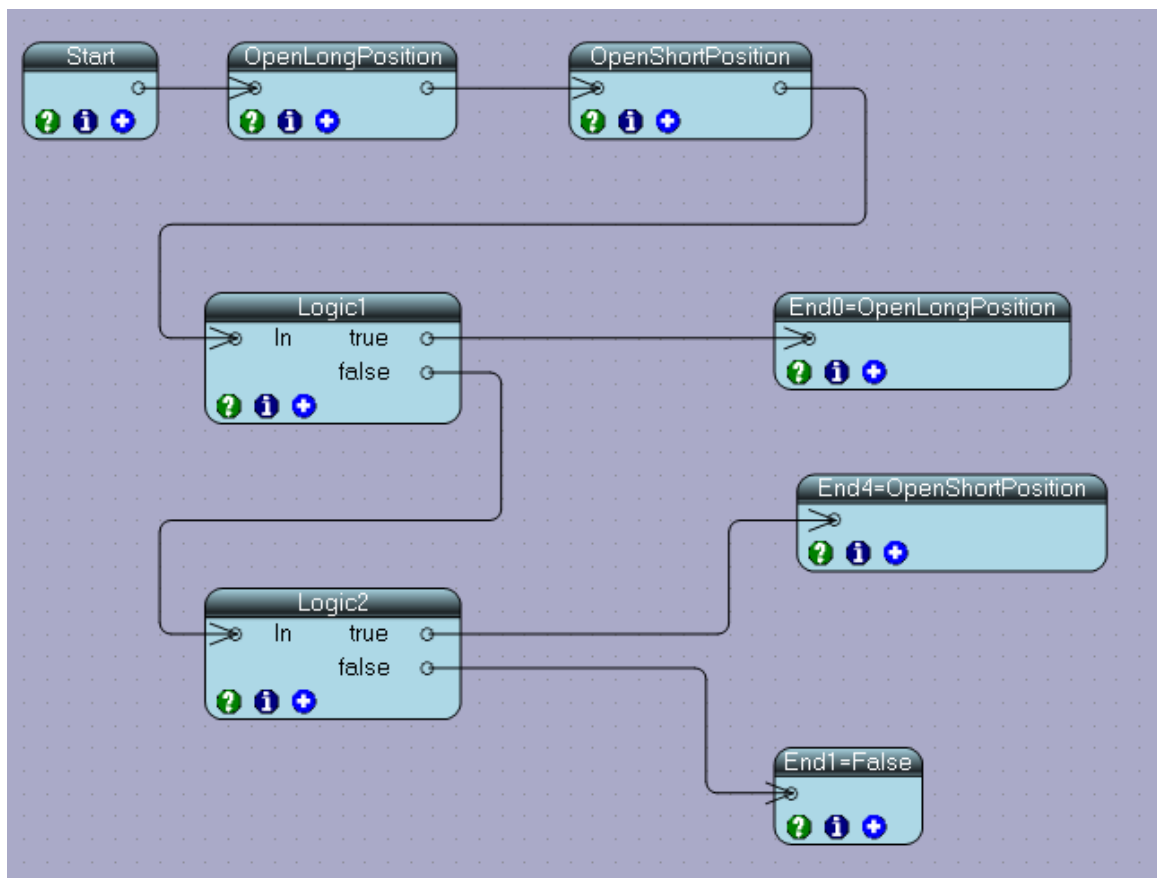

- This drawing performs this logic:
 - Sets the OpenLongPosition and the OpenClosePosition values.
 - Calls the Adx function and compares its value to AdxBuyLevel.



- If the Adx value is greater than AdxBuyLevel, the component ends with, or returns, OpenLongPosition.
- If the Adx value is Not greater than AdxBuyLevel, the Adx value is compared to the AdxSellLevel.
- If the Adx value is less than AdxSellLevel, the component ends with, or returns, OpenShortPosition.
- If the Adx value is Not less than AdxSellLevel, the component ends with, or returns, False.

Build the “GetTradeSignal” Component/Drawing

- With the “GetTradeSignal” drawing open, click the “Build” button on the upper right portion of the VTS application.
- The log file on the bottom of the VTS application will display the results of the build.

Putting it all Together

To complete the system, we are going to do the following:

- Check if it is OK to open a position by calling the “OkToTrade” component.
- Check if there is a trade signal by calling “GetTradeSignal”. If there is, open a position, otherwise exit.

Add the “OkToTrade” Logic

- **Select the “IndicatorSystem” drawing:** Click the tab page labeled “IndicatorSystem”.
- **Add a Logic element to “IndicatorSystem” drawing:** Select the “Add New Items” tab from the toolbox, select and drag the Logic icon onto the “IndicatorSystem” drawing. Configure the Logic element to evaluate “OkToTrade” “EQUAL TO” “true” and click OK.



Add the “OpenLongPosition” Logic

- **Add the “GetTradeSignal” component element to “IndicatorSystem” drawing:** Select the “Component” tab from the toolbox, expand the “User” menu, select and drag the “GetTradeSignal” menu item onto the “IndicatorSystem” drawing.
- **Add an “OpenLongPosition” variable to the “IndicatorSystem” drawing:** Select the “Variables” tab from the toolbox, expand the “User” menu, select and drag the “OpenLongPosition” menu item onto the “IndicatorSystem” drawing.
- **Add (another) “Logic” element to “IndicatorSystem” drawing:** Select the “Add New Items” tab from the toolbox, select and drag the decision icon onto the “IndicatorSystem” drawing. Configure the Logic element to evaluate “GetTradeSignal” “EQUAL TO” “OpenLongPosition” and click OK.

Add the “OpenShortPosition” Logic

- **Add (another) “Logic” element to “IndicatorSystem” drawing:** Select the “Add New Items” tab from the toolbox, select and drag the decision icon onto the “IndicatorSystem” drawing. Configure the Logic element to evaluate “GetTradeSignal” “EQUAL TO” “OpenShortPosition” and click OK.
- **Create and Add the Trading Functions to the Drawing**

This system will open a long position if the Adx value is above a certain threshold, or it will open a short position if the Adx value is below a certain threshold. The MQL function used to open trading positions is called “OrderSend”.

Add an OrderSend Function to Open a Long (Buy) Position

- Select the “Functions” tab from the toolbox.
- Expand the “Trade” menu.
- Select and drag the “OrderSend” menu item onto the “IndicatorSystem” drawing.
- A window will be displayed showing the parameters of the “OrderSend” function.



- For the second parameter “cmd”, select “OP_BUY”.
- Select OK.
- The function element will be created and added to the “IndicatorSystem” drawing.
- The function will be named “OrderSend”, where n is a number.

Add an OrderSend Function to Open a Short (Sell) Position

- Select the “Functions” tab from the toolbox.
- Expand the “Trade” menu.
- Select and drag the “OrderSend” menu item onto the “IndicatorSystem” drawing.
- A window will be displayed showing the parameters of the “OrderSend” function.
- For the second parameter “cmd”, select “OP_SELL”.
- Select OK.
- The function element will be created and added to the “IndicatorSystem” drawing.
- The function will be named “OrderSend”, where n is a number.

Add a TRUE EndPoint Element to the “IndicatorSystem” Drawing

- Select the “Add New Item” tab of the toolbox.
- Select and drag an Endpoint icon from the toolbox to the drawing.
- A window will appear with the EndPoint name and value.
- Select “True” from the pull-down menu.
- Select OK to accept the shown values.

Add a FALSE EndPoint Element to the “IndicatorSystem” Drawing

- Select the “Add New Item” tab of the toolbox.
- Select and drag an Endpoint icon from the toolbox to the drawing.
- A window will appear with the EndPoint name and value.
- Select “False” from the pull-down menu.
- Select OK to accept the shown values.

We now have all of the elements needed to finish the “IndicatorSystem” System. The drawing should look similar to this:

iExpertAdvisor™

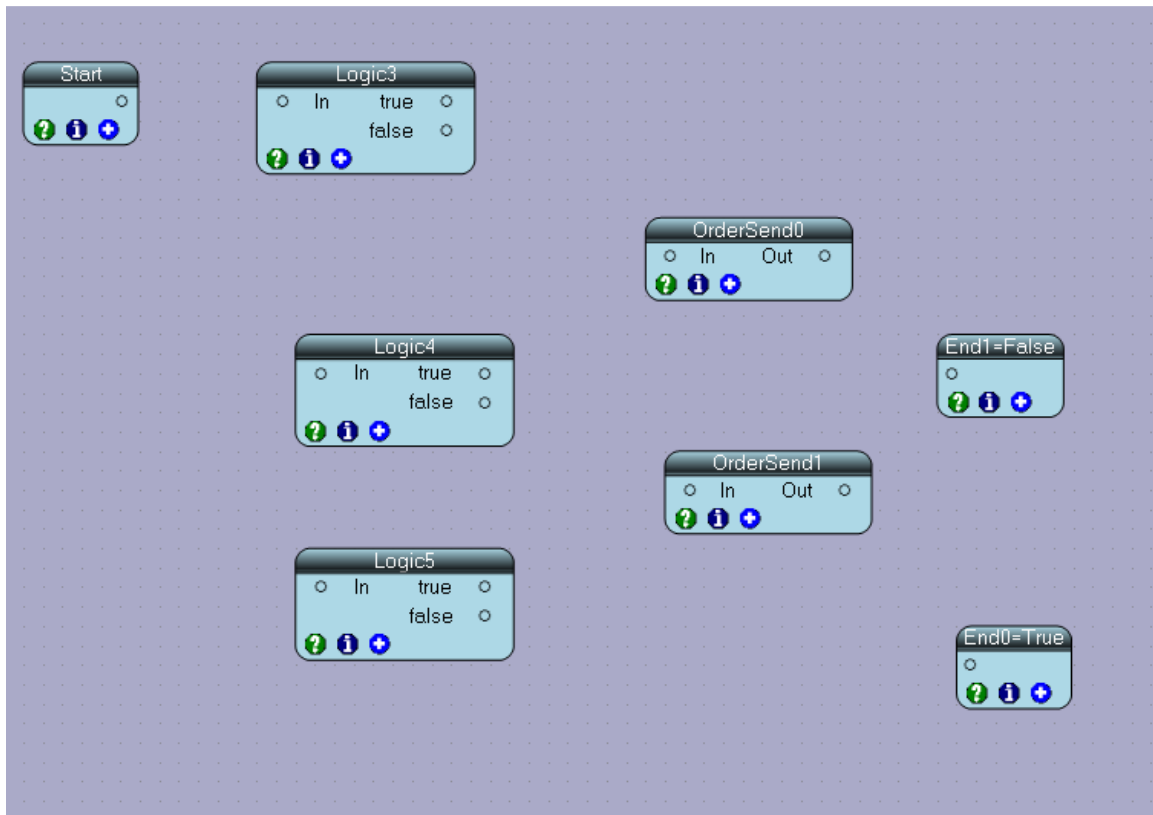

Connect the Elements to Form the Logic.

The final drawing should look similar to this:

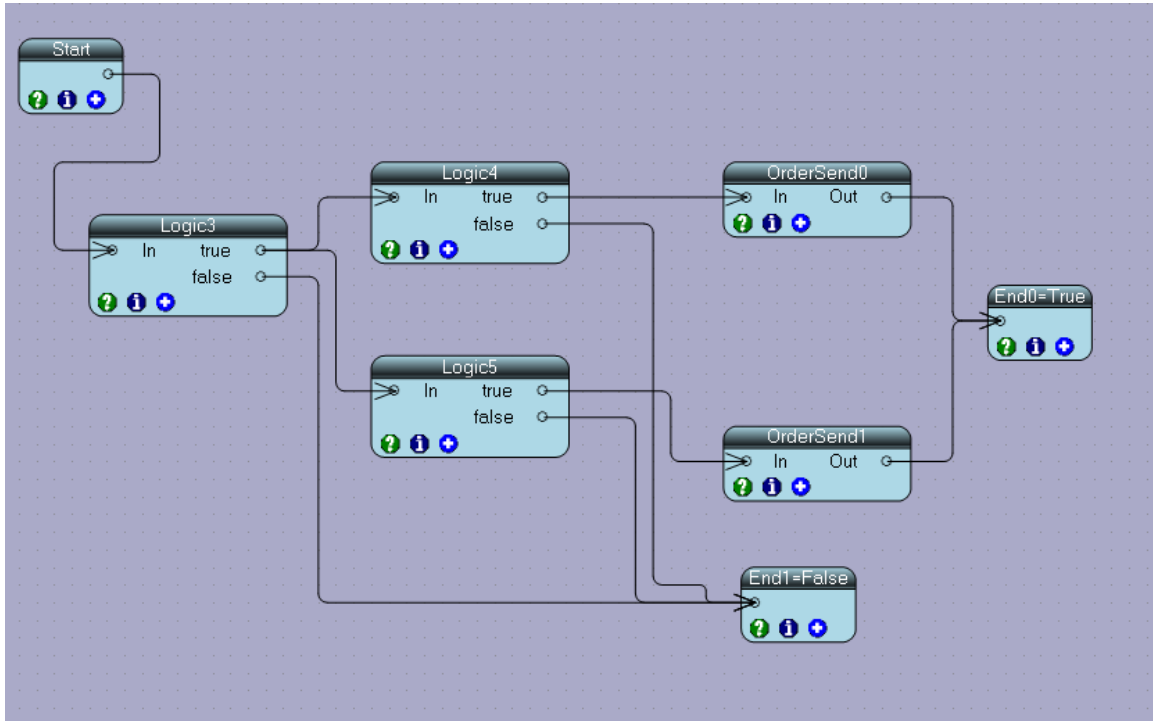

Build the “IndicatorSystem”

- With the “IndicatorSystem” drawing open, click the “Build” button on the upper right portion of the VTS application.
- The log file on the bottom of the VTS application will display the results of the build.
- This will create the Expert Advisor MQL file and ex4 file.
- The MQL file will be name IndicatorSystem.mq4
- The ex4 file will be name IndicatorSystem.ex4.
- The files will be saved in the “experts” directory of your MetaTrader platform.
- When you open your MetaTrader Terminal platform, you should see the “IndicatorSystem” expert advisor available to be attached to a price chart.

If your VTS application is configured correctly, you should be able to open the MetaTrader application by clicking the “Editor” button on the upper right-hand corner of the VTS window. This should also automatically load the “IndicatorSystem.mq4” file within MetaEditor.